

<p><b>FS-72U</b> (ND 8).</p> <p><b>XL 1.6X*</b> XL 1.6X</p> <p><b>XL3.4-10.2mm 3X</b> 3X 600 TV ND 35mm</p> <p><b>XL5.5-88mm 16X IS II</b> ND</p> <p><b>XL5.4-86.4mm 16X</b> 2 ND</p> <p><b>EF XL</b> EF</p> <p><b>EF XL 1:</b> 가 EF 7.2X</p>	<p><b>FU-1000 CRT</b> 1.5 CRT</p> <p><b>ZR-1000</b> LANC 가</p> <p><b>420EX/550EX</b> XL 1: SLR-FA-200 가</p> <p><b>VL-10LI FA-200</b> 10W XL 1: 가</p> <p><b>MA-100 MA-200</b> MA-100 XLR 2 MA-200 XLR 4 가 BNC 가</p>
<p><b>HC-3100</b> 가</p>	<p><b>CB-910</b> 가</p> <p><b>CH-910</b> 2 XL 1: 2</p> <p>BP-915: 50 BP-930: 105 BP-945: 135</p>
<p><b>DVM-E60 DVM-CL</b></p>	

\*16X IS II 16X



이 마크는 순정품 또는 비디오 액세서리를 표시하는 것입니다. 계층의 비디오 장비를 사용하실 때는 동일한 마크가 부착된 제품이나 액세서리를 구입하여 사용할 것을 권장합니다.

**Canon**

[www.lgcamera.co.kr](http://www.lgcamera.co.kr)

**LG상사**

LG 11 20  
[www.lgcamera.co.kr/www.canondigital.co.kr](http://www.lgcamera.co.kr/www.canondigital.co.kr)

TEL: 1544-5775 FAX: 02)719-5263

A/S

© CANON INC. 2001

PRINTED IN KOREA

**Canon**

**Go Digital  
Go Canon**

Mini DV

**XL1S**

3CCD  
DIGITAL VIDEO  
CAMCORDER

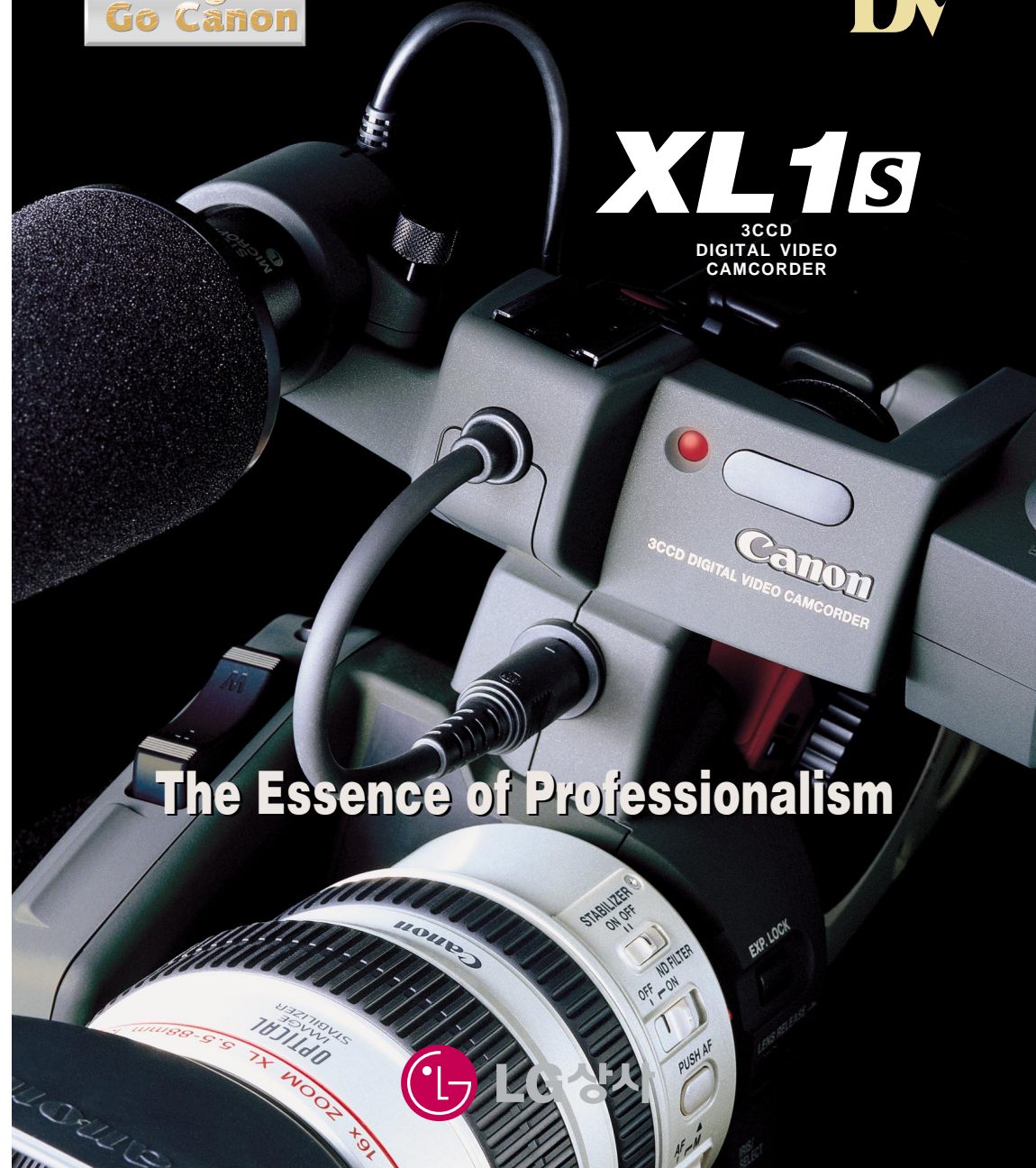

**The Essence of Professionalism**

**LG상사**

Mini DV Digital Video Cassette



XL1s

XL1s

가,

XL1s

IEEE1394 DV

XL1s IEEE 1394

가

DV

가

DV



DV

500

가  
DV

25%

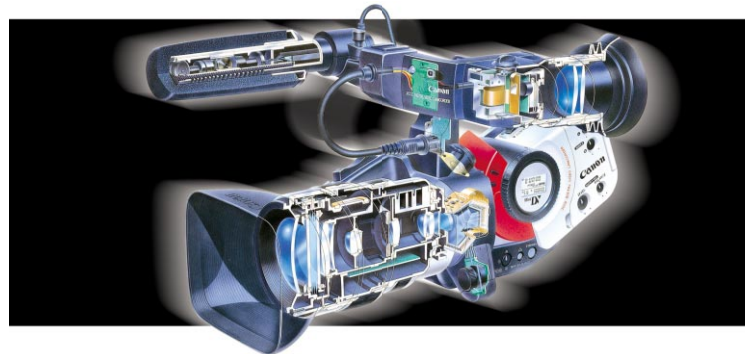

3CCD  
XL1s  
CCD  
( ) DV

CCD

**3CCD**  
Super Low Light  
3CCD

가

가

**PIXEL SHIFT**

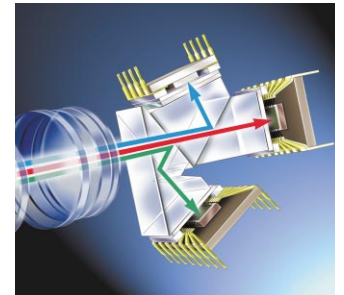

XL1s

3 CCD

가

72

150%

4dB

가

가



가

2,160mm **XL 1st** 24mm XL

XL EF 35mm  
가



3X

3X DV  
가



3.4mm 10.2mm 24mm 72mm  
600TV

16X

IS II

600 TV  
DV TV 500  
250 TV  
100



ND AF



16X

1.6X

**XL 1st**  
16X

16x  
가 1.6x 가



ND

SuperRange  
OPTICAL  
IMAGE  
STABILIZER

( )  
( )  
CCD 가

가

16X



이미지 흔들림 방지기능 ON

이미지 흔들림 방지기능 OFF



EF

EOS 35mm

EF

**XL 1st**  
7.2X

**XL 1st**  
35mm 가



1200mm EF



37가

XL1가

가

3 CCD

TV XL1가

TV

가

1 700 (SP)

XL1가

6

XL1가

30

가

35mm



16:9

XL1가

가

16:9

가

AE

가

16:9 가

가

가

16:9 가

가

6가

16:9

DV

16:9

XL1가

16:9

TV

가

가

가



(Tv/Av)

Tv Av

가

35mm SLR

가

XL1가

CRT

가

가

가

. Tv

1/60

1/15000

XL1가

. Av

가



f/1.6

f/16

XL1가

SMPTE Color Bars

XL1가 SMPTE

3가

가



AE

AE

AE

Av

XL1가

2X



1/30, 1/15

1/8

3가

가

Gain

XL1가

-3dB, 0dB,

+6dB, +12dB, +18dB

+30dB

가

3가

가

Gain



가

. 80, 85, 90, 95

가

100% 5가

가

Phase



30

, 1

, 5

10

0.5

, 1

, 1.5

2

VCR

(5

가



**XL1S**  
S- (RCA)  
TV, VCR

가 ) ( VCR MA-200 BNC 가 VCR

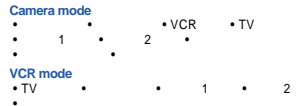

**4**  
**XL1S**  
16bit (2, 48KHz)  
12 bit (4, 32KHz)

VU  
**XL1S**  
Mic



**PCM STEREO**

**XL1S**  
가

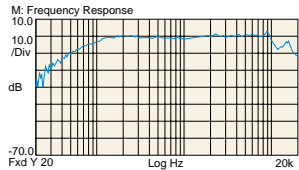

**DV XL1S**  
DV

**XL1S**

가 ) ( VCR MA-200 BNC 가 VCR



**XLR**  
MA-200  
4 XLR 가  
BNC 가



**AV**

VCR  
(, SP  
) (12 bit



AV/C

DV

**XL1S**

20

**XL1S**

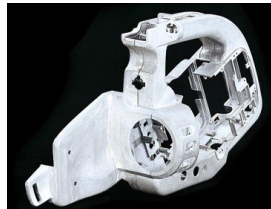

가

**XL1S**



**XL1S**

**XL1S** ( (37

**SLR-**

**XL1S** FA-200 E-TTL  
(420EX 550EX)  
SLR 가 가

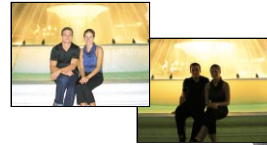

**ZR-1000**

LANC



**XL1S**

가 가



**CH-910**  
2  
MA-200



**LANC**  
LANC 가

**ZR-1000**



**Canon XL1S**

: 7.2 V DC  
(, AF=ON): 8.7 W  
(, AF ON)  
: EIA (525  
60 ) NTSC  
: 2  
: TTL  
가  
: 1/15,000  
: 2 lx(XL 5.5-88mm  
1/8 )  
: 100 lx  
: 72mm (XL )  
: 0.7  
LCD ( 180,000 )  
: 4  
: 3.5mm  
: 600  
(IEEE1394 )  
Output level:  
: RCA , : 223 x 214 x 415 mm  
: 1.7kg ( )  
1 Vp-p/75 )

S- : 4 DIN,  
1 Vp-p (Y signal),  
0.286 Vp-p (C signal)  
: RCA (L, R), 2  
4dBm(47k load)/3k  
Input level:  
: RCA (L, R), 2  
11dBV/47k (LINE),  
35dBV/600 (MIC ATT),  
55dBV/600 (MIC),  
: 3.5mm  
: -59dBV(600mic)/  
600  
: 0° - 40  
: 223 x 214 x 415 mm  
: 1.7kg ( )  
2.86kg ( )

**XL1S**



**XL1S**  
16X XL 5.5-88mm IS II  
BP-930  
CA-910  
DC-900 DC  
SS-1000  
WL-D3000  
SP-100  
S-150 S-  
STV-150

- ① 스테레오 마이크
- ② 뷰파인더 포커싱 링
- ③ 뷰파인더
- ④ 아이 컵
- ⑤ 어깨 끈 부착용 바
- ⑥ ND FILTER 스위치
- ⑦ STABILIZER 스위치
- ⑧ LIGHT 버튼
- ⑨ AUDIO MONITOR 버튼
- ⑩ POWER 다이얼
- ⑪ EJECT ▲ 버튼
- ⑫ 포커싱 링
- ⑬ 줌 링
- ⑭ 자동/수동 포커스 스위치
- ⑮ PUSH AF 버튼
- ⑯ EXP. LOCK 버튼
- ⑰ IRIS/SELECT 다이얼
- ⑱ LENS RELEASE 스위치
- ⑲ MENU 버튼
- ⑳ GAIN 다이얼
- ㉑ 화이트 밸런스 선택기 노브
- ㉒ WHITE BALANCE 설정 버튼
- ㉓ STANDBY 버튼
- ㉔ 어깨 패드 SP-100, 마이크패드 MA-100, MA-200용 소켓
- ㉕ 어깨 패드 SP-100
- ㉖ EYE POINT SELECT 스위치
- ㉗ START/STOP 버튼
- ㉘ LOCK 레버
- ㉙ 액세서리 슈
- ㉚ (헤드폰) 단자
- ㉛ PHONES LEVEL 다이얼
- ㉜ 델리 램프
- ㉝ 리모트 센서
- ㉞ 핸들 줌 컨트롤
- ㉟ PHOTO 버튼
- ㊱ 시작/정지 버튼
- ㊲ 델리 램프



- ㊳ 리모트 센서
- ㊴ 3CCD
- ㊵ XL 렌즈 마운트
- ㊶ 전자 점접
- ㊷ CUSTOM 키 1
- ㊸ USER PRESET (SELECT) 버튼
- ㊹ CUSTOM 키 2
- ㊺ USER PRESET (ON/OFF) 버튼
- ㊻ L/R 다이얼(AUDIO 2)
- ㊼ LEVEL 다이얼(AUDIO 1)
- ㊽ BALANCE 다이얼(AUDIO 1)
- ㊾ AE 셔프트 다이얼
- ㊿ 오디오 LCD 패널
- 1 REC LEVEL 스위치(AUDIO 2)
- 2 REC LEVEL 스위치(AUDIO 1)
- 3 INPUT SELECT 스위치(AUDIO 1)
- 4 DC out 단자
- 5 비디오 단자
- 6 S-video 단자
- 7 Audio 1 RCA 잭
- 8 REC(녹화) SEARCH + 버튼
- 9 EVF DISPLAY 버튼
- 10 D. E. /BARS ON/OFF 버튼
- 11 SHUTTER ▲ 키
- 12 SHUTTER ▼ 키
- 13 REC(녹화) SEARCH - / (녹화 리류) 버튼
- 14 D.E./BARS SELECT 버튼
- 15 AUDIO DUB. 버튼
- 16 FF ▶▶ 버튼
- 17 REW ◀◀ 버튼
- 18 AV INSERT 버튼
- 19 REC ● || 버튼
- 20 PLAY/PAUSE ▶ || ◀ 버튼
- 21 STOP ■ 버튼
- 22 AUDIO 2 RCA 잭 (R)
- 23 AUDIO 2 RCA 잭 (L)
- 24 플래시 어댑터 단자
- 25 REMOTE ◀ 단자
- 26 DV 단자
- 27 BATT. RELEASE 버튼
- 28 삼각대 소켓
- 29 그림 벨트
- 30 PHOTO 버튼
- 31 그림 줌 컨트롤

- 1 ZOOM 버튼
- 2 전송부
- 3 PHOTO 버튼
- 4 START/STOP 버튼
- 5 DATA CODE 버튼
- 6 ▲ 커서 키
- 7 EXECUTE 버튼
- 8 ZERO SET MEMORY 버튼
- 9 AUDIO DUB 버튼
- 10 MIX BALANCE 버튼
- 11 SEARCH 버튼
- 12 FF ◀◀ 버튼
- 13 ◀/▶ (후레이밍 단위 역방향) 버튼
- 14 x2 버튼
- 15 STOP ■ 버튼
- 16 조그/셔틀 다이얼
- 17 SELF TIMER 버튼
- 18 ON SCREEN 버튼
- 19 MENU 버튼
- 20 ▲ 커서 키
- 21 AUDIO MONITOR 버튼
- 22 PLAY ▶ 버튼
- 23 SEARCH SELECT 버튼
- 24 REW ◀◀ 버튼
- 25 ◀/▶ (후레이밍 단위 역방향) 버튼
- 26 REC PAUSE 버튼
- 27 PAUSE || 버튼
- 28 SLOW ▶▶ 버튼

